

Ladder Mount and Climb Face with Round Members Cable Safe Climb System

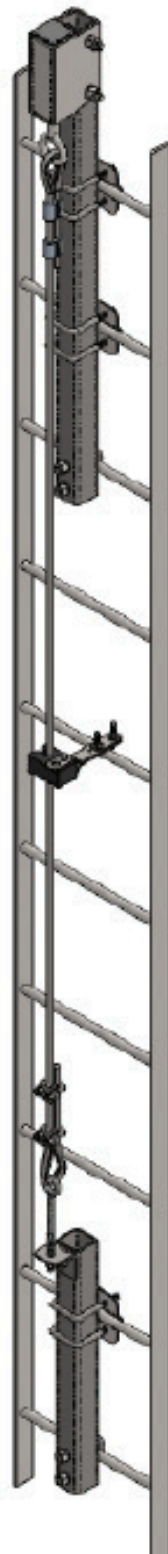

TTWG-500-SE/SMC

Patented

3/8" dia. cable system, up to 4-person safe operation

Removable dual cam Wire Grab (optional)

Automatic hands free climbing

Fixed ladder standard shown, custom systems available

Proudly Made in the USA

Sealed anchor head w/ impact attenuator

Permanently secured forged eyebolt

Permanently swaged cable sleeves

Adjustable clamp brackets

Steel square tubing supports

3 Point of Connection

HT U-Bolts

Removable wire rope grab (Optional)

Cable stand-off (every 25 ft.)

3/8" dia. wire rope

Removable cable clamps & thimble

Steel anchor brackets

Adjustable anchor eyebolt

CONFORMS TO THE FOLLOWING SPECIFICATIONS & RECOMMENDATIONS:

- ANSI Z359
- OSHA 1910/1926
- CSA Z259
- EN 353.1
- SEMC
- TIA-EIA 222



Questions/concerns contact:

LSCB-INST - Rev 2



Round member installations shown. Angle member installations also available upon request.

Ladder Mount Installation

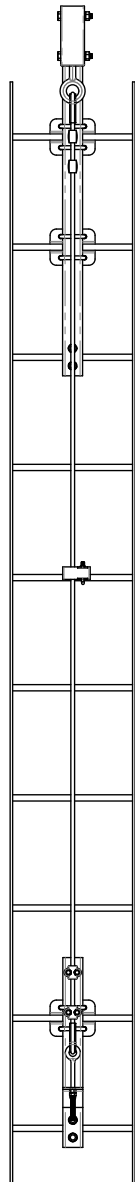

Climb Face Installation

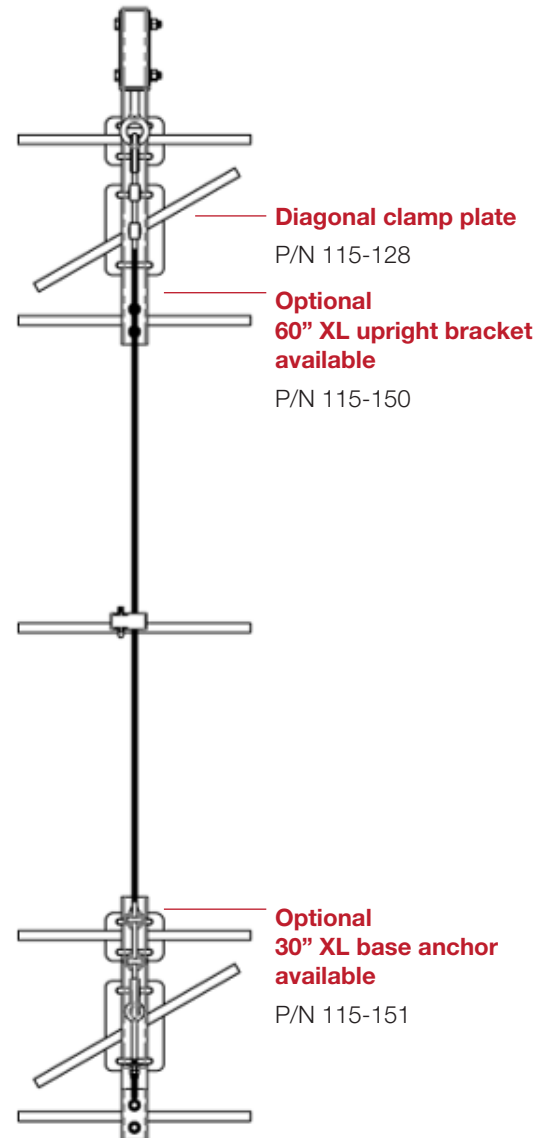

TUF-TUG safe climb options include but are not limited to

- Ladder Mount (Galvanized)
- Ladder Mount With Stainless Steel Wire Rope
- Ladder Mount With Stainless Steel Components And Wire Rope
- Extra Long Ladder Mount (Galvanized)
- Extra Long Ladder Mount With Stainless Steel Wire Rope
- Extra Long Ladder Mount With Stainless Steel Components And Wire Rope



Questions/concerns contact:

LSCB-INST - Rev 2





WARNING!: YOU MUST READ AND FULLY UNDERSTAND OR HAVE THESE INSTRUCTIONS EXPLAINED TO YOU BEFORE USING THIS EQUIPMENT. FAILURE TO OBSERVE THE LIMITATIONS, CAUTIONS AND WARNINGS IN THESE INSTRUCTIONS COULD RESULT IN SEVERE PERSONAL INJURY OR DEATH.

Equipment users must be fully trained as a competent climber and conversant with all regulatory requirements applicable to the workplace in which the fall protection equipment is to be used. If in doubt, contact your local OSHA office for clarification. These instructions are not a substitute for a formal climbing and Fall Protection Training program. Such training should include information about local circumstances, rules and regulations applicable to the work situation, a hands-on opportunity to learn how to wear and attach equipment properly, instructions about adequate anchor points and proper techniques for securing and connecting lanyards, drop lines or lifelines, and guidance and demonstration on how to inspect and maintain the equipment.

Tuf-Tug Cable Safety Climb Systems are designed to meet the performance requirements of OSHA/ANSI for personnel fall arrest on fixed ladders. It utilizes a 3/8" solid core cable with factory swaged sleeves to provide an anchorage capable of maintaining a min. 5,000 lb. tensile load. An impact attenuator is incorporated in the anchor head to help dampen any extreme shock loads that may occur as a result of a fall. Cable stand offs are provided with systems over 25 ft. to stabilize and maintain the cable in a good operable condition. Base anchor bracket is supplied with a line adjustment mechanism for a 220 lb. – 420 lb. system tension load.

NOTE: This cable safety climb system is intended to be used as part of a complete personal fall protection system. All components, subsystems and connectors should be compatible and meet the appropriate ANSI/OSHA requirements for the intended application. Substandard or non-approved components could compromise the reliability of the system and jeopardize the safety of the user. USE ONLY TUF-TUG SUPPLIED OEM COMPONENTS TO ASSEMBLE THE COMPLETE CABLE SAFE CLIMB SYSTEM. DO NOT ATTACH TO OTHER MANUFACTURER'S, NON-APPROVED SAFE CLIMB MOUNT BRACKETS TO TUF-TUG CABLE AND HEAD ASSEMBLY. ALTERING SYSTEM DESIGN WILL VOID ALL CLAIMS AND WARRANTY. The Tuf-Tug wire rope grab (TTWG-500) and climbers/positioning full body harness (TTFBH-C/P), should be used in conjunction with the cable safety climb system to assure maximum reliability.

Factored live loads +75 lb. Average Tuf-Tug system weight = minimum top anchorage load calculations.
For 2-4 climbers per OSHA/ANSI, TIA and SEMC:

- (2) Person factored live loads = 3,240 lbs.
- (3) Person factored live loads = 3,705 lbs.
- (4) Person factored live loads = 4,170 lbs.

Assess the workplace for hazards such as heat, flames, chemical, electrical, environmental, sharp objects, moving equipment, unstable/uneven or slippery surfaces. Identify the potential hazards and plan for the installation to avoid dangerous paths, obstructions and zones. Have an emergency rescue/contingency plan in place in the event that an accident may occur per rescue/retrieval section.

LADDER MOUNT INSTALLATION:

START AT THE TOP AND WORK YOUR WAY DOWN

- A Before the last ladder or tower section of the installation is set, Attach upright mast to the top/center of ladder rungs with the supplied U-Bolts and clamp plates as shown. Secure nuts on bolts per the following guidelines for maximum security $\varnothing 3/8$ -16 = 25 ft. lbs. and $\varnothing 1/2$ -13 = 40 ft. lbs. Make sure the mast is square and centered to the ladder.
- B Attach head assembly with cable to the upright mast with the supplied $\varnothing 1/2$ " bolts. Allow cable to hang freely down face of ladder to ensure that mount is installed square to the climb. Torque $\varnothing 1/2$ " diameter fasteners to approximately 40 ft. lb.
- C Climbing down ladder attach a cable stand-off every 25 ft. with the supplied U-bolt and insert cable into slot. Alternate slot openings left and right to cable center as the run is installed. Torque 3/8" fasteners to approximately 25 ft. lb.
- D Secure the base anchor bracket in line with cable to the lowest rungs on the ladder with the eyebolt facing up and tighten $\varnothing 3/8$ " U-bolts to 25 ft. lb.

Questions/concerns contact:

LSCB-INST - Rev 2





- E With Anchor Eyebolt fully extended up, thread cable through thimble and loosely attach cable clamps. Pull on free end of cable to take slack out of line and secure nuts on cable clamps to approximately 40 ft. lb. torque.
- F Tension cable lifeline by tightening nut on anchor eyebolt until 220 lb. tension is achieved
- G Check security of installation by pulling down on cable to assure the Safe Climb System has been tensioned.
- H If, not repeat steps E & F until line is properly tensioned.
- I Attach I.D. Plate at base of ladder and fill out installation date and number of allowable users.

NOTE: For climb face installations: A diagonal clamp plate may be substituted for the horizontal rung clamp plate (Reference Illustration for Parts Listing and Installation)

Reference specific installation application for the climb facility in question. Inspect installation for obvious miscues from the ground, and/or refer to the SEMC document for detailed information. Points of caution may include one or more of the following: excessive corrosion, loose cable, loose brackets, over tensioned system/ deployed eyebolt, etc. If any of these items are encountered and cannot be remedied, climb with extreme caution. A secondary fall protection system may be warranted until the issue can be identified, classified and/ or corrected. Also, be aware of the current environmental hazards that these elements represent and plan for a safe climb accordingly with approved JHA/JSA documentation.

Use:

Cable safety climb system should be used in accordance to the SEMC PPE inspection outlined with the TTWG-500 Wire Rope Grab instructions that are supplied with specific bracket pack installation information. A climb log of the system's use should be kept per the specific climb facility's installation.

If the system arrests a fall, it should be removed from service and replaced to assure maximum reliability. If this is not immediately feasible, a qualified person/climber can make an assessment to the damage and provide short term recommendations/remediation.

Inspect system before each use for corrosion, wear, damage and/or defects during each climb per SEMC document. Record findings per the climb log. If system shows signs of any hazards, contact owners for corrective action immediately. It is recommended an annual or regular scheduled inspection should be made of the Cable Safety Climb System along with the supporting structure to assure its functionality.

:

For a safety climb that is subjected to a fall, and rescue is required, the competent rescuer executing the rescue shall be required to assess the means available to efficiently and safely rescue the climber to avoid suspension trauma. If the best means is to use the existing wire rope safety climb that has been exposed to a fall, then the competent rescuer shall be required to, at a minimum:

- A) Verify that the equipment utilized, including but not limited to the safety climb, meets the intended requirements for rescue as outlined by the manufacture(s).
- B) Visually inspect the safety climb for changed conditions from the last written PPE inspection in compliance with section 5 of the SEMC document to assess the usability of the safety climb.
- C) Communicate the plan to use the safety climb system with others involved with rescue procedures.
- D) The competent rescuer shall ensure that use of the system will not create a greater hazard than other means.
- E) Once the rescue is complete, the wire rope safety climb is to be reported and tagged out until corrective action has been taken.

Always keep these instructions and records with the system in a place that is easily accessible to all users

Questions/concerns contact:

LSCB-INST - Rev 2

|

|



Ladder Mount Installation

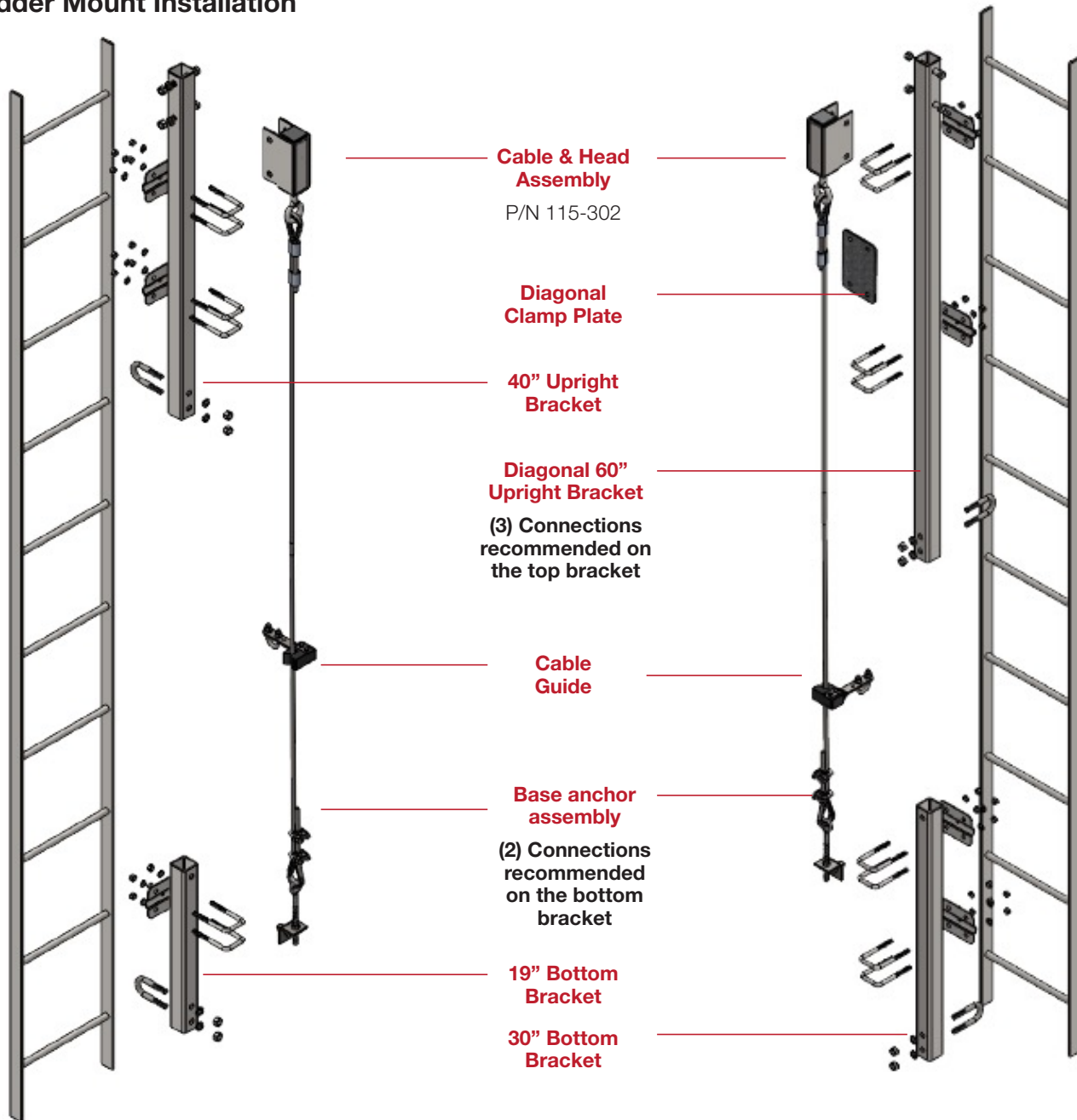

Ladder Mount kits include the following hardware:



x1 Diagonal Clamp Plate



x4 Ladder Rung Clamp Plates



x8 Square U-Bolts & Fasteners



x1 Head Assembly Fasteners



x1 Base Anchor Attachment Kit



x2 Round U-Bolts & Fasteners

Questions/concerns contact:

LSCB-INST - Rev 2



All users of fall protection equipment must be in good health, must not have a medical history of conditions that could be aggravated by a fall, must be mentally fit and must not be under the influence of alcohol or drugs. Inattention to these factors could cause falls, serious injury or death.

Any component which has arrested a fall should be removed from service and replaced.

Never alter or use a Safety Climb System that has been altered – the potential malfunctions could result in serious injury.

Do not attempt to repair damaged equipment. Remove from service and replace.

Discard equipment if there is any evidence of excessive wear, damage or malfunction.

ALWAYS BE CAREFUL! Your Safety is important to us. If a situation is questionable, consult a qualified professional for proper procedures or reference appropriate specification.

WARRANTY:

“Limited 1 Year Warranty to Original Using Buyer” - TUF-TUG Cable Safe Climb Systems are warranted for 1 year against defects when operated under normal conditions, within their rated capacities and in accordance with the operating instructions and use considerations.

Any part or mechanism that is recognized as defective by TUF-TUG Products will be replaced or repaired Free of Charge during the warranted period if it is returned, prepaid, to the factory with a return authorization. Claims for labor, delays, or damages are not covered by this warranty. This warranty does not apply if the unit has been altered, modified, or repaired by any source other than TUF-TUG Products.

Environmental / Corrosion considerations

- A) Macro-environmental: Installation exposure warranty for normal macroscopic rural, suburban, and temperate marine environments with moderate chemical, salinity, sulfur dioxide, and relative humidity, equals 10 years.
- B) Micro-environmental: Tuf-Tug safety climbs with increased exposure to near coastal (within 25 miles), tropical marine environments, high winds, chemical exposure, salinity exposure, sulfur dioxide exposure, and high humidity locations, anticipated time to first maintenance is 5 years.
- C) Extreme Micro-environmental: Direct exposure within 5 miles of the corrosive catalyst, to the afore mentioned microscopic extreme environments, including, but not limited to; direct coastal exposure, continuous exposure to tropical marine environments, high winds, caustic chemicals, high salinity, streaming sulfur dioxide, and extreme high humidity could reduce the first time to maintenance warranty period to TIA inspection requirements. These sites shall be identified and targeted for additional TIA maintenance and condition assessment to assure the validity of the safe climb system installation on the structure that has extreme environment exposure. Recommended first to maintenance inspection cycle should not exceed 2-year maximum timeline.

“Quality is long remembered after the price has been forgotten”

Questions/concerns contact:

LSCB-INST - Rev 2



TTWG-500 TUF-TUG WIRE ROPE GRABS

(ANSI Z359, CSA Z259 & EN 353.1)

WARNING! YOU MUST READ AND FULLY UNDERSTAND OR HAVE THESE INSTRUCTIONS EXPLAINED TO YOU BEFORE USING THIS EQUIPMENT. FAILURE TO OBSERVE THE LIMITATIONS, CAUTIONS AND WARNINGS IN THESE INSTRUCTIONS COULD RESULT IN SEVERE PERSONAL INJURY.

Equipment users must be fully trained in and conversant with all regulatory requirements applicable to the workplace in which the fall protection equipment is to be used. If in doubt, contact your local Safety office for clarification. These instructions are not a substitute for a formal climbing and Fall Protection Training Program. Such training should include information about local circumstances, rules and regulations applicable to the work situation, a hands-on opportunity to learn how to wear and attach equipment properly, instructions about adequate anchor points and the proper techniques for securing and connecting lanyards, drop lines or lifelines, and guidance and demonstration on how to inspect and maintain the equipment. End user should have access to these instructions for reference.

SYSTEM REQUIREMENTS: TUF-TUG Wire Rope Grabs are designed to meet the performance requirements of ANSI Z359 CSA Z259 & EN 353.1 for personnel fall arrest on fixed ladders. It is intended for use on $\phi 3/8$ " solid core cable system with an anchorage capable of maintaining a minimum of 5,000 lbs. tensile load. (NOTE: Specials are provided for other size wire rope and will be specifically identified on the housing of the mechanism. IE: $\phi 1/4$ ", $\phi 5/16$ " and/or $\phi 1/2$ "). It is recommended that the TTWG-500 be attached to a full body harness with a front "D" ring (TTFBH-C/P) with a 2" Self Locking Carabiner/Hook that meets the proper safety requirements. The maximum length of the connector to the wire grab from the harness should not exceed 9 inches.

NOTE: This Wire Rope Grab is intended to be used as part of a complete personal fall protection system. All components, subsystems and connectors should be compatible and meet the appropriate OSHA/ANSI/CSA/EN requirements for the intended application. Substandard or non-approved components could compromise the reliability of the system and jeopardize the safety of the user.

BEFORE EACH USE: Inspect mechanism for proper operation by pivoting cams back and forth. Movement should be free and easy without binding. Check units for deformation, defects, corrosion or wear that may affect the free movement and/or operation of the mechanism. Units with signs of any of the above check items, should be removed from service and discarded.

KNOW YOUR WORKPLACE: Assess the workplace for hazards such as heat, flames, chemical, electrical, environmental, sharp objects, moving equipment, unstable/uneven or slippery surfaces. Identify the potential hazards and plan the installation to avoid dangerous paths, obstructions and zones. Have an emergency rescue/contingency plan in place in the event that an accident may occur.

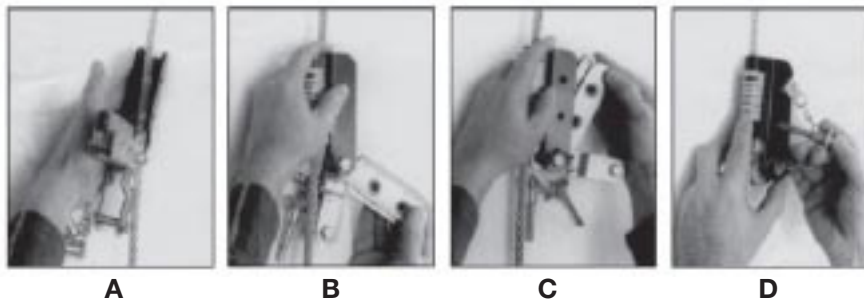

- A. Release pull pins by depressing end buttons and remove from unit.
- B. Open unit by pivoting clamp bar assembly away from housing
- C. Attach to cable as shown in Figures A and B with arrow up
- D. Close unit by pivoting cams onto rope, making sure that arrow is pointing up as shown in Figures B and C.
- E. Reinsert pins into housing making sure that ball detent passes through assembly (Figure D).
- F. Check security of pins by trying to remove without releasing button.
- G. Work cams back and forth and run fall arrester up and down to assure functionality and freedom of movement.
- H. A short 5-foot test climb is recommended to confirm the automatic hands-free function of the wire grab on the safe climb system.
- I. Test installation by pulling down sharply on the attachment eye to ensure that the mechanism locks onto the cable with full body weight and avoid incorrect use.

Questions/concerns contact:

LSCB-INST - Rev 2





USE

- A After wire grab has been secured to safety cable, attach to safety harness front “D” Ring with an approved double locking carabiner/hook. (Installation of wire grab to safety line can take place after harness attachment if desired). Always keep wire grab above user’s center of gravity to minimize fall potential, distance and impact loading. Sternal D Ring connection shall be used for Fall Arrest – TTWG-500 Attachment ONLY.
- B To ascend safety cable, climb ladder in a normal fashion with torso centered and close to the mechanism. Wire grab is designed to rotate freely around cable safe climb system and will operate with the user sideway leaning up to 15° left or right off center. Thereof, the mechanism should self-align and/or follow the user up the safe climb system with a normal steady/even pull. The wire grab should also work freely up and down forward leaning on incline up to 15° off the vertical, up and down. Always keep a minimum safe operating distance between your torso and TTWG-500.
- C If cable system has guides/supports, remove cable from stand-offs as they are encountered and reinsert after passing. DO NOT REMOVE WIRE ROPE GRAB FROM SAFETY CABLE to pass over guides, supports or standoffs, etc., If obstructed, make a secondary OSHA approved attachment to the structure (lanyard, rope grab, etc.) prior to doing so. For 100% Tie Off, never manually override Wire Grab lever during operation, this may compromise the function of the braking mechanism.
- D To descend safety cable, again climb down ladder in a normal fashion with torso centered and close to the mechanism. This will keep the attachment lever up, disengaging the clamping cams and allow the wire grab to freely lead the climber.
- E If the lever is pulled back past center by leaning back, the clamp cams will engage the cable and the wire grab will lock onto cable safe climb system. To unlock the mechanism, simply move upward to pivot the lever over center. This will allow the wire grab to track the user and operate freely.
- F Always keep a safe distance of 10 ft. (3m) from potential hazards to avoid contact if a fall occurs.
- G Make sure to check security of harness and adjust for snug fit prior to ascent and descent.
- H IF THE WIRE GRAB ARRESTS A FALL, REMOVE IT FROM SERVICE AND REPLACE IT

CARE

- A After use always clean mechanism, wipe with a new towel, and lubricate pivot points with machine oil. Inspect unit for wear, damage and/or defects. If the mechanism becomes wet, allow to air dry naturally.
- B If wire grab shows signs of excessive wear or a defective condition, remove it from service and replace it. If in doubt return it to the factory for evaluation.
- C You must ensure that the product markings remain legible during the entire lifetime of the product.
- D Keep your wire grab/fall arrester in a safe/dry storage location to prolong its service life and ensure its functionality.
- E Never alter or use a wire rope grab that has been altered, the potential malfunction could result in serious injury or death.

All users of fall protection equipment must be in good health, must not have a medical history of conditions that could be aggravated by a fall, must be mentally fit and must not be under the influence of alcohol or drugs. Inattention to these factors could cause falls, serious injury or death!

Any component which has arrested a fall must be immediately removed from service.

Do not attempt to repair damaged equipment. Remove from service immediately.

Discard equipment if there is any evidence of excessive wear, damage or malfunction.

ALWAYS BE CAREFUL! Your safety is important to us. If a situation is questionable, consult a qualified professional for proper procedures or reference appropriate specifications.

For other TUF-TUG Safety Hardware; Confined Space Tripods, Man Winches, Rope Grabs and/or Anchor Brackets and/or Full Body Harnesses, contact us at 937-299-1213 or Email us at Info@Tuf-Tug.com

Questions/concerns contact:

LSCB-INST - Rev 2

